

THORN
LIGHTING



CONTUS

FOR INDUSTRY

Linear lines of light installed
in market-leading times



**WE
MAKE
LIGHT
WORK**

EFFICIENT, FLEXIBLE TRACK SYSTEM

**WITH BEST IN CLASS INSTALLATION TIME
AND EASY MAINTENANCE**

Thorn's Contus track and batten system has been designed to boost productivity, enhance safety and enable people to efficiently undertake tasks across a wide range of industrial applications such as manufacturing and logistics.

Contus provides uniformity of light, through its precision lens optics with a variety of beams including shelf beam, narrow beam and wide beam optics appropriate for different areas within the industrial space.

Contus track is highly flexible; suspend or mount from a wall or ceiling. The patented tool-free electro-mechanical twist and lock mechanism allows Contus batten luminaires to be rapidly installed, saving time and cost. Contus is fully adjustable if the room layout of an industrial area needs to change over time.

Contus is ideal for industry and logistics building refurbishment, as well as new-build projects. Both of which have their own complexities when it comes to energy efficiency, cost reduction and installation time constraints.

The battens are protected from dust and dirt ingress, preserving the light efficiency through the precision optics. With up to 163 lm/W efficacy, up to 10,000 lumens and 50,000 hours lifetime (L80:B10), Contus can be trusted to perform.



Industry



Logistics



Retail

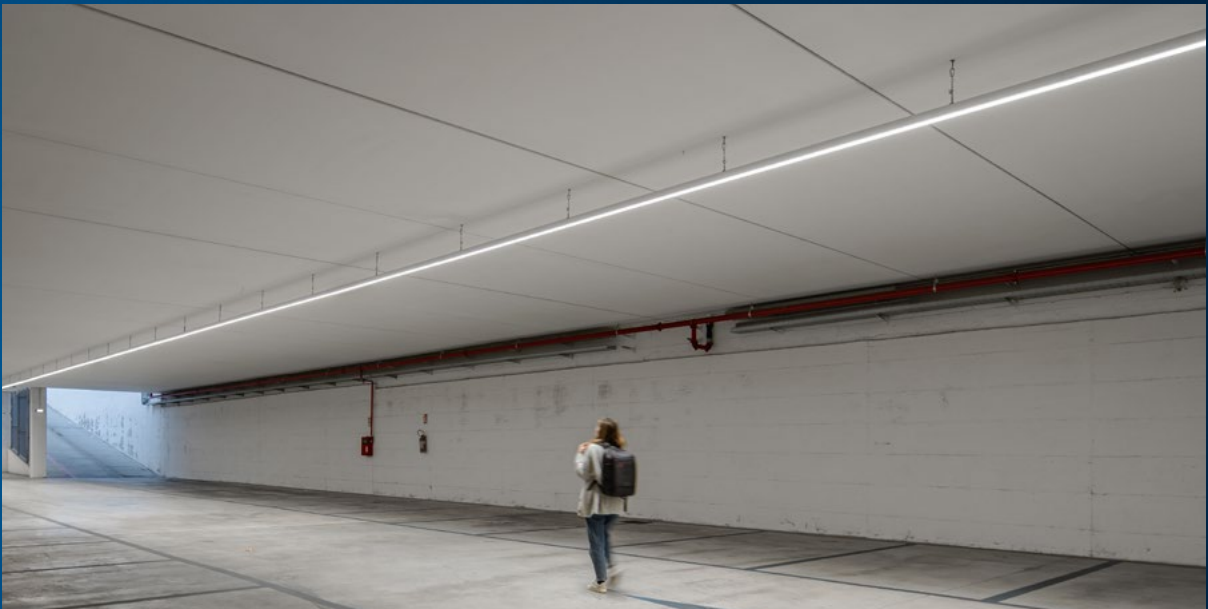

ON THE RIGHT TRACK FOR INDUSTRY

Manufacturing and logistics are two applications that often involve large open spaces, requiring high levels of illumination, with the additional requirement to reduce cost of installation and maintenance. It is expensive to supply power cables to each luminaire in a large space, and so a low cost installation method is preferred. Track allows for a cost effective infrastructure and flexibility in the lighting design. Contus can be configured with a choice of four batten optics – wide, very wide, shelf and narrow beam, depending on the task.

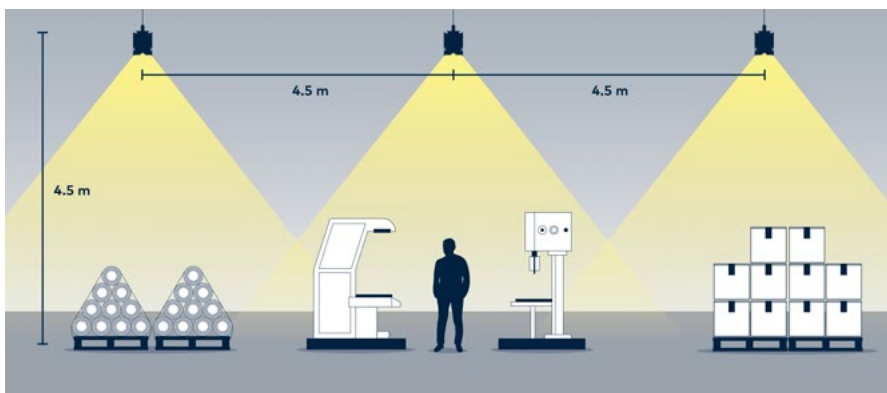

PRODUCTION AREAS

Emphasis is placed on uniform illumination of production areas. Contus has been designed to be installed regardless of the positioning of equipment and tools. A choice of **wide beam** and **very wide beam** optics allows for repositioning of machines and production areas over time, without the need to modify the placement of the luminaires.

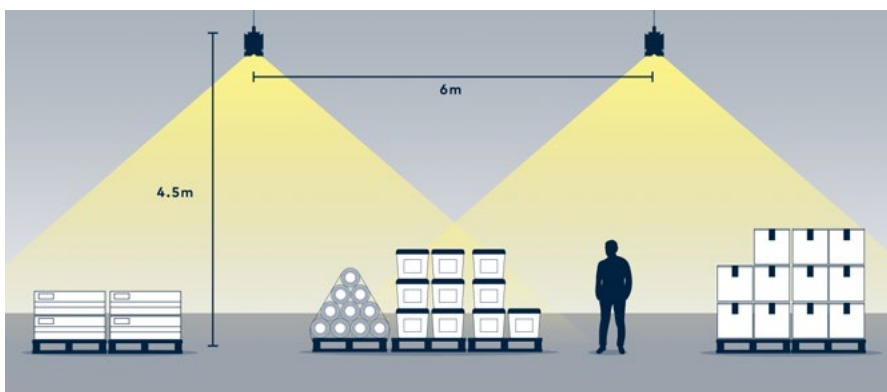

ASSEMBLY AND DESPATCH AREAS

These can vary in usage from large tasks with low visual difficulty to technical, intricate tasks with high visual difficulty. Hazards such as forklift trucks must be highlighted. Contus battens with a **wide beam** or **very wide beam** optic will allow for modular working areas, with high luminous flux but low perceived glare.

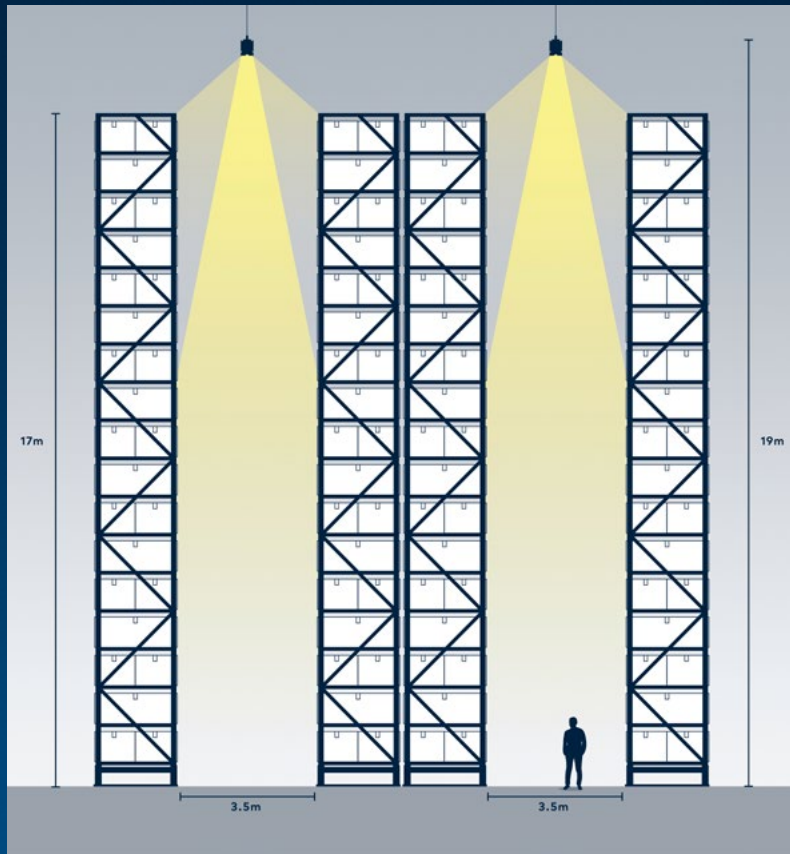

STORAGE – HIGH RACK AREAS

Warehouses and logistics areas often have very little natural daylight, and so their high rack areas require careful consideration of illumination to ensure that task areas are lit correctly and safely. Storage areas are often a combination of open and shelf racking with high shelves and narrow aisles. For medium to high shelving the **narrow beam** optic has been specifically designed to match the relevant shelving situation, resulting in optimised lighting of the aisle zones and uniform illumination of shelf surfaces.

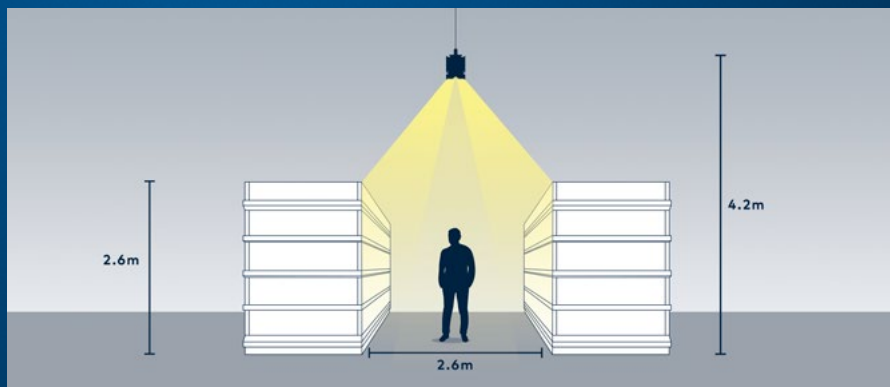

STORAGE, PICKING AND PACKING – LOW RACK AREAS

For lower-level shelving found in component storage and picking and packing areas, the **shelf beam** optic provides high-intensity, uniform illumination of shelf surfaces to help minimise picking errors.

RISING TO THE CHALLENGE

Consistency of light, even in challenging environments such as mechanical or chemical industrial locations. Contus battens have lenses made of impact-resistant (IK07) and UV-resistant PMMA for strong protection.

Resistance to heat and cold is also important, and Contus can be used in locations where the continuous ambient temperature ranges from -10°C up to 35°C . The absence of wiring containing halogen ensures that the amount of fumes is reduced in the rare event of a fire.

Resistance to dust and dirt minimises the cleaning of the luminaire and provides an extended maintenance cycle. This will be very convenient in busy industrial facilities, where access to the Contus luminaires will be limited.

LONG LIFE AND FEWER LUMINAIRES

Contus combines excellent luminous efficacy (up to 163 lm/W) with a long lifetime (50,000 hours at L80). Thanks to innovative optics and high lumen packages, even the distance between the continuous rows can be significantly increased. In summary, fewer luminaires may be required thanks to the wide beam and very wide beam optics, resulting in a faster return on investment.

The combination of benefits allow customers to budget for fewer luminaires, saving investment costs and energy. Good for your budget and good for the environment.

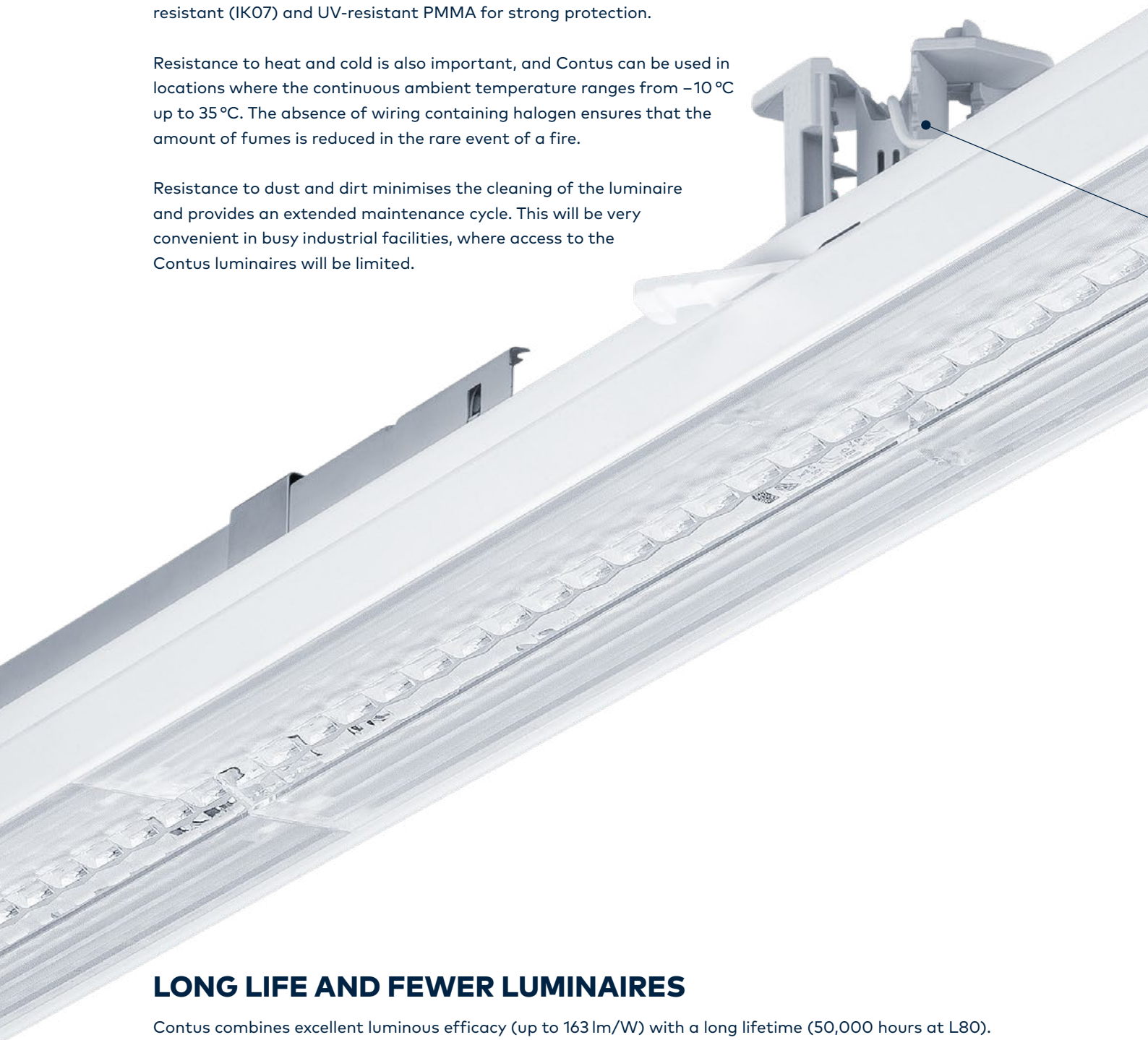

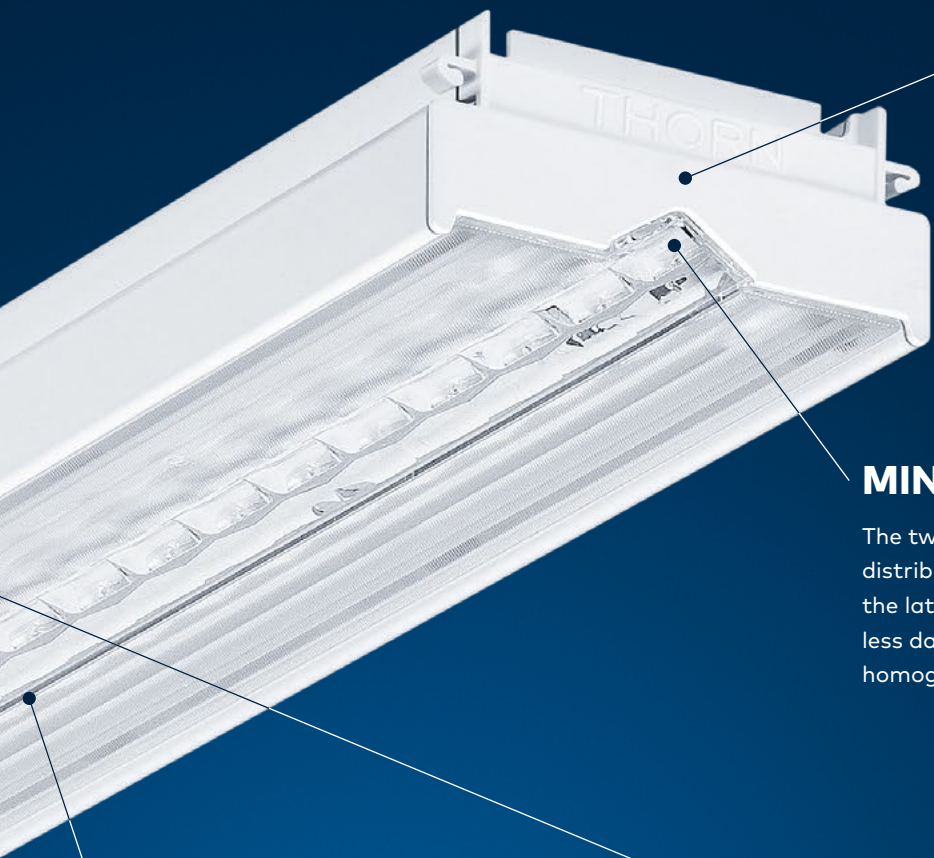

LOW MAINTENANCE

Resistance to dust and dirt minimises cleaning and provides an extended maintenance cycle – very convenient in busy warehouses, logistic hubs and factories, with very limited access to the luminaires.

MINIMISED GLARE

The twin-lens optic design of Contus battens distributes the light precisely from the centre to the lateral edges. The luminaire therefore appears less dazzling and the light emission surface more homogeneous than other competitor track systems.

TWIST & LOCK MECHANISM

The tool-free electro-mechanical twist and lock mechanism allows Contus batten luminaires to be rapidly installed and maintained throughout their life, saving time and cost.

HIGH COLOUR RENDERING

With a colour rendering index of CRI > 80 and colour temperatures of 3000 K and 4000 K, Contus demonstrates its high-quality of light, ideal for industry.



EXTRA LENGTH

Contus battens are available in 1, 1.5 and 2 m lengths. The 2 metre batten offers more benefits than the shorter variants, as around 25 % fewer luminaires will be required to light the space, resulting in an installation time reduced by up to 40 %, compared with shorter continuous row luminaires.

TASK OPTIMISED OPTICS

A choice of four specially designed Contus batten luminaires, each with unique optical characteristics, can be installed on the Contus track system. Thorn Contus battens will ensure that different areas of a factory or logistics hub will be lit in the most optimal way.

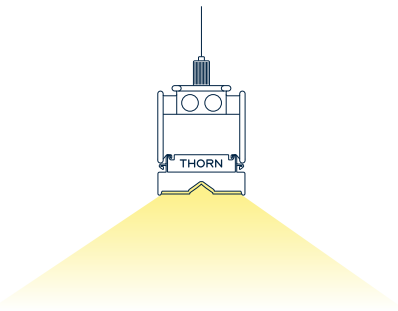

WIDE BEAM

The wide beam optic is equally suitable for handling decorative as well as technical tasks. Its medium-wide light distribution is ideal for lighting shelf surfaces and aisle zones. It also illuminates surfaces without shelves uniformly, such as manufacturing areas.

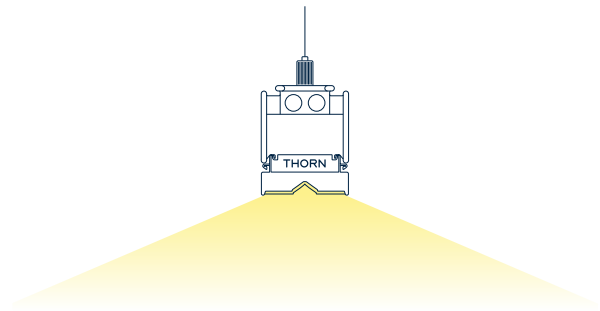

VERY WIDE BEAM

Never before have industrial production areas and logistics packing stations been illuminated with so few luminaires, whilst maintaining the best quality of light. Despite the high luminous flux, the perceived glare is very low.



NARROW BEAM

Specially developed for use in industrial and engineering applications, the narrow beam optic ensures efficient, uniform illumination of the vertical fronts of shelving and racking. With a maximum mounting height of around 19 m, it easily copes with medium and large room heights.

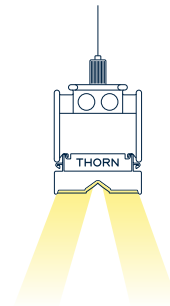

SHELF BEAM

The symmetrical light distribution provided by this optic focuses on shelf surfaces; aisle zones are not as brightly lit. This way, attention is directed to the items that are on display.

MODULAR INFRASTRUCTURE



THE CONTUS TRACK SYSTEM

Comprising of standard modular components in lengths of 1, 2, 2.5 and 4 metres. This makes lighting design and implementation easy thanks to gradation in 0.5 m increments. Customers will save time with planning and installation.

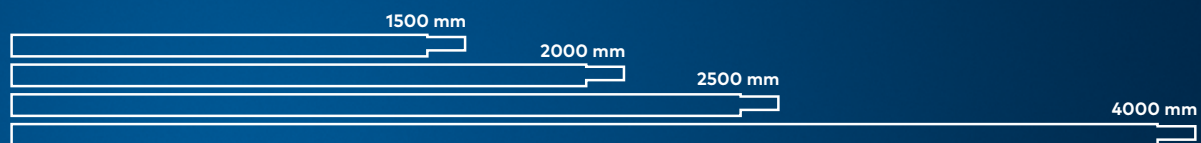

BLANK END TRACK

Supplied as a 1 metre channel, this can be cut to length by the customer. This ensures a seamless finish and allows for electrical feed-out, so you can join multiple Contus lines together.



NODE CONNECTORS

Using various node connectors, Thorn's Contus continuous-row lighting system can be assembled and combined in a myriad of variants. Contus L and T nodes open up many different options for creative design using linear light. The structures themselves can therefore become a fundamental part of the interior design.

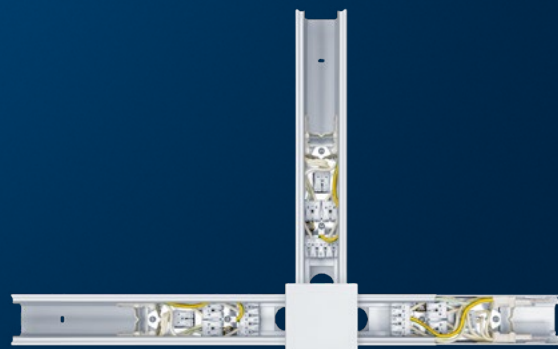

SUSTAINABLE, ECONOMIC LIGHTING

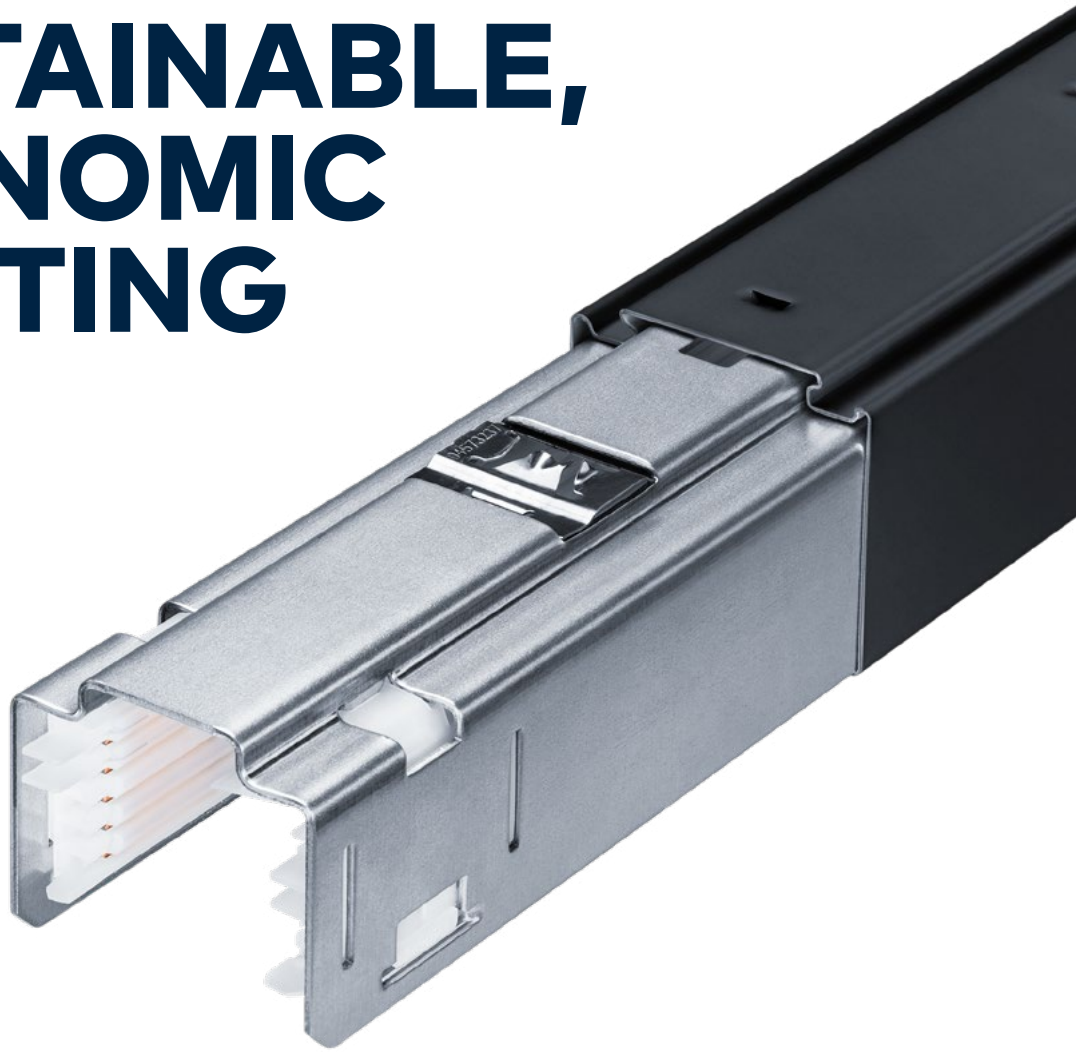

L1 L2 L3 N ⏚

5 connections for power supply (5 x 2.5 mm²)

Separately switchable 3-phase circuits for simple light control.

EN1 EN2 EL1 EL2

4 poles for two independent emergency lighting circuits (4 x 1.5 mm²)

Two independent emergency lighting circuits allow optimal integration of emergency lighting with the general lighting.

D1 D2

2 control lines with DALI protocol for brightness control (2 x 1.5 mm²)

Efficient, flexible, customised lighting control.

For industrial companies with long production times or shift-rotation for always-open logistics, energy management is important. It starts with energy-efficient and dimmable Contus luminaires and continues with the built-in DALI control line in the Contus track, which allows sensors and lighting controls to be effortlessly integrated, allowing light to be managed according to demand.

QUICK AND EASY INSTALLATION



Consultants, contractors, wholesalers and electricians will all be impressed with the simplicity of configuration and installation of Contus. It provides a streamlined infrastructure with high flexibility and fast, tool-free installation.

A comparison was made of eight different continuous-row LED track systems, with regard to the installation time required for a 15 metre long arrangement.

Conducted by an independent external consultant, the results illustrate that Contus can be installed considerably faster than comparable products.

Up to 55 % of time is saved in comparison to continuous-row LED systems of lighting competitors. Installation time saved equals money saved, and this can be a significant factor in any new-build or refurbishment scheme, where linear lighting is required in multiple locations.

Thorn's Contus solution can also save more than 61 % of time on average, compared to conventional T5/T16 solutions.

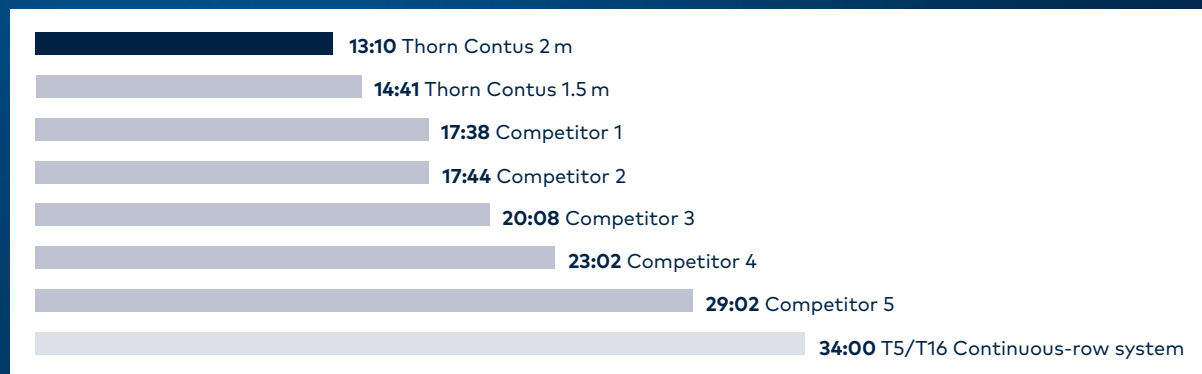

TEST CONDITIONS SETUP:

Length of continuous-row 15 m, ceiling height 3.7 m, height of continuous-row 3.2 m, 2 installers with ladders.

The time indicated is for mounting, excluding unpacking and assembly of suspension systems (approximately 30 min).

AN ECOSYSTEM OF CONTUS COMPATIBLE LUMINAIRES

An ever-growing ecosystem of indoor luminaires is now available to complement the Contus track system. Take advantage of the rapid-installation of Contus to place high bays, battens and emergency lighting exactly where you need them to be.

All the Contus compatible luminaires are designed to simply 'twist and lock' into Contus. This is the time to elevate the lighting in your manufacturing plants, logistic centres and warehouses.



HIPAK

Premium performance high bay with excellent efficiency and wireless control

HiPak is a highly efficient one-for-one replacement for conventional industrial luminaires – and now with an efficiency of up to 181 lm/W, it promises a quicker payback than ever.

With a choice of three sizes and six lumen outputs up to 35,000 lm, HiPak is an ideal choice for point-for-point replacements on retrofit projects. HiPak features a range of control options to enable even greater energy savings. HiPak offers both microwave and passive infrared sensors and of course, works seamlessly with our range of basicDIM Bluetooth® wireless control options. Quality is assured with a 100,000 hour lifetime (L80).

For more information: thornlighting.com/HIP4



HIPAK EMERGENCY BATTERY

An effortless way to provide excellent emergency lighting levels in industrial areas

The battery uses the latest LiFePO4 technology to be reliable, lightweight and cadmium-free.



POPPACK

The electrician's go-to batten

A firm favourite for decades with more than 70 million units sold, PopPack is now Contus compatible. It is ideal for industry applications where manufacturing, storage, service rooms, corridors, general circulation and other functional rooms can be found.

With the fluorescent tube ban across western Europe, PopPack is the perfect one-for-one LED replacement for single and twin T8/T5 fluorescent battens, and the simple and efficient solution for new installations.

For more information: thornlighting.com/POPL



CONTUS COMPATIBLE BATTENS



AQUAFORCE PRO

Durable and chemical-resistant luminaire

Available in a choice of two materials; Polycarbonate (PC) or Polymethyl Methacrylate (PMMA), Aquaforce Pro is a versatile Contus compatible luminaire that can be used in range of demanding environments.

Resistant to water vapour, dust and dirt, as well as a tough shock-resistant body means Aquaforce Pro is well suited to multiple applications including manufacturing, logistics, indoor car parks and back of house.

With connectivity options, Aquaforce Pro can enhance spaces through presence detection and offer additional energy and cost savings.

For more information: thornlighting.com/AQUP

CONTUS COMPATIBLE EMERGENCY LIGHTING

VOYAGER ONE

Multifaceted emergency luminaire platform

Voyager One is a platform for emergency lighting rather than a single luminaire. It can easily be converted into a safety sign luminaire and adapted to all possible conditions with the availability of multiple accessory optics for different mounting heights on Thorn Contus track, including those of more than 20 metres, ideal for industry applications where high ceilings and tall racking configurations are commonplace.

For more information: thornlighting.com/VOYO





VOYAGER BLADE 2

Sleek and simple

Voyager Blade's Contus compatible body is robust and easy to mount. The base housing is identical for both recognition ranges, reducing complexity. Voyager Blade is supplied with four pictograms (Up, Left, Right, Down) ensuring flexibility at installation.

For more information: thornlighting.com/VOB2

IDEAL FOR OFFICE AREAS



IQ WAVE SP

Comfort without compromise

Lighting which is too dim, too bright, poorly distributed or flickering can cause health problems including eyestrain, headaches, dry eyes and blurred vision. Today's office areas are filled with glossy devices, connected via video conferencing and operational for increasingly long hours. Taking into consideration these characteristics along with natural daylight (where the space allows), the Contus compatible IQ Wave SP offers advanced glare and lighting control for comfort and productivity.

Designed by Thorn's expert optical team, IQ Wave features our unique MV-Tech light optic. The M represents the shape of the light, emitted upwards from the central optic, and bouncing back down and through the diffuser to create great task lighting. The V represents the light which has been widely dispersed outwards from the centre to create a soft lit appearance and great lighting for faces and spaces.

For more information:
thornlighting.com/IQSU



CONTUS COMPATIBLE SENSORS

THE NEXT LEVEL OF CONTROL

Designed specifically to fit Contus track, simply plug-in to control connected DALI luminaires and unlock further energy savings.

With both wired and wireless (Bluetooth®) options, the perfect control solution is easily configured to your individual requirements. PIR versions are available for three different mounting heights, meaning that no matter the application, Thorn have the right solution for your needs.

- Low Ceiling (LC) for 2-5 m mounting height
- Medium Ceiling (MC) for 5-8 m mounting height
- High Ceiling (HC) for 8-16 m mounting height



CONTUS

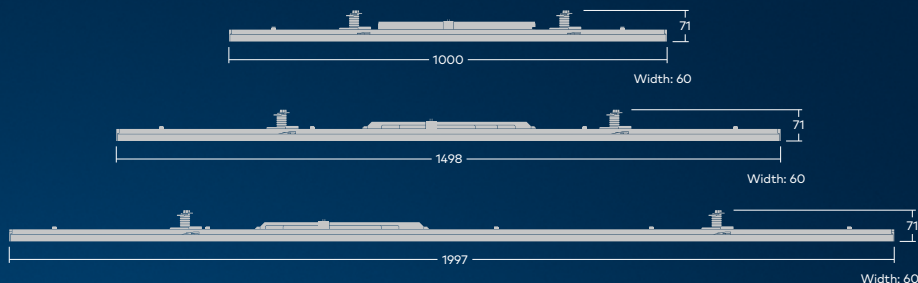

	1000 mm	1500 mm	2000 mm
	128 LEDs	192 LEDs	256 LEDs
	3000 K / 4000 K		
	HE: 3700 lm (1000 mm), 5500 lm (1500 mm), 7400 lm (2000 mm) HO: 5200 lm (1000 mm), 8000 lm (1500 mm), 10,000 lm (2000 mm)		
	Up to 163 lm/W		
CRI	80		
UGR	< 22		
	IP20		
	HE: -10 °C to 35 °C, HO: -10 °C to 30 °C		
	IK07		
	L80 @ 50,000 h		
	Wide Beam (WB), Very Wide Beam (VWB), Narrow Beam (NB), Shelf Beam (SB)		
	White (WH), Black (BK)		
	Switchable / DALI		
	ECD		
	MacAdam 3		



As a globally leading luminaire manufacturer, Thorn Lighting provides a five-year warranty for its complete product range within all European Countries.
thornlighting.com/guarantee

Thorn Lighting is constantly developing and improving its products. All descriptions, illustrations, drawings and specifications in this publication present only general particulars and shall not form part of any contract. The right is reserved to change specifications without prior notification or public announcement. All goods supplied by the company are supplied subject to the company's General Conditions of Sale, a copy of which is available on request. All measurements are in millimetres and weights in kilograms unless otherwise stated.
10/2024 (INT)

**WE
MAKE
LIGHT
WORK**